



Department of Building & Zoning Services

Scott Messer, Director
111 N. Front St, Columbus, Ohio 43215

DEPARTMENT OF BUILDING
AND ZONING SERVICES

DECK REQUIREMENTS

PERMIT FEE: (as of January 2019)

\$200 – Includes 3 inspections for footers, framing, and final (see inspection section below).

BUILDING PERMIT APPLICATION:

One completed copy per project.

HOMEOWNER’S PERMIT AFFIDAVIT:

Attached to Building Permit Application. A licensed contractor is required if homeowner is not doing the construction.

PLANS REQUIRED:

TWO (2) sets of the following:

- Site Plan**
- Footing Plan**
- Framing Plan**
- Elevation with Connection Details**
- Guard Rail / Hand Rail Detail**
- Stair Detail**

INSPECTIONS REQUIRED:

1. **Footing** – After all post holes are excavated with all loose debris and water cleaned out but before concrete is placed.
2. **Framing** – After all posts and beams are in place with joist hangers, lag/carriage bolts (see details), and fasteners exposed.
3. **Final** – After all work is completed including stairs, handrails and guardrails.

Ledger Board Attachment: Access to the home must be granted to verify that the connection fully extends beyond the inside face of the band joist when using a ledger board to support the deck. A minimum of two connections must be exposed.

The homeowner or contractor is not required to accompany the inspector during inspections unless an inspection requires access to an occupied structure. However, it is the responsibility of the contractor to notify the homeowner of inspections in order to allow free access to the property, i.e., unlocked gates, no pets in yard, etc.

The building permit and drawings must be on site and available for the inspector. If the homeowner or contractor cannot be available for the inspection, the permit and approved drawings must be left in a waterproof bag or container clearly marked “building permit” and left in a visible location.

All work shall comply with the 2019 Residential Code of Ohio Section 507.

DECK PLANS AND DETAILS

SITE PLAN:

Must show:

1. Property Lines with dimensions
2. Setback lines (if any)
3. Residence outline, garage, and all out-buildings with dimensions

A mortgage survey or Franklin County Auditor Map can be used as a base map for the site plan. Dimensions and proposed deck must be drawn on neatly with a pen and ruler (example below).

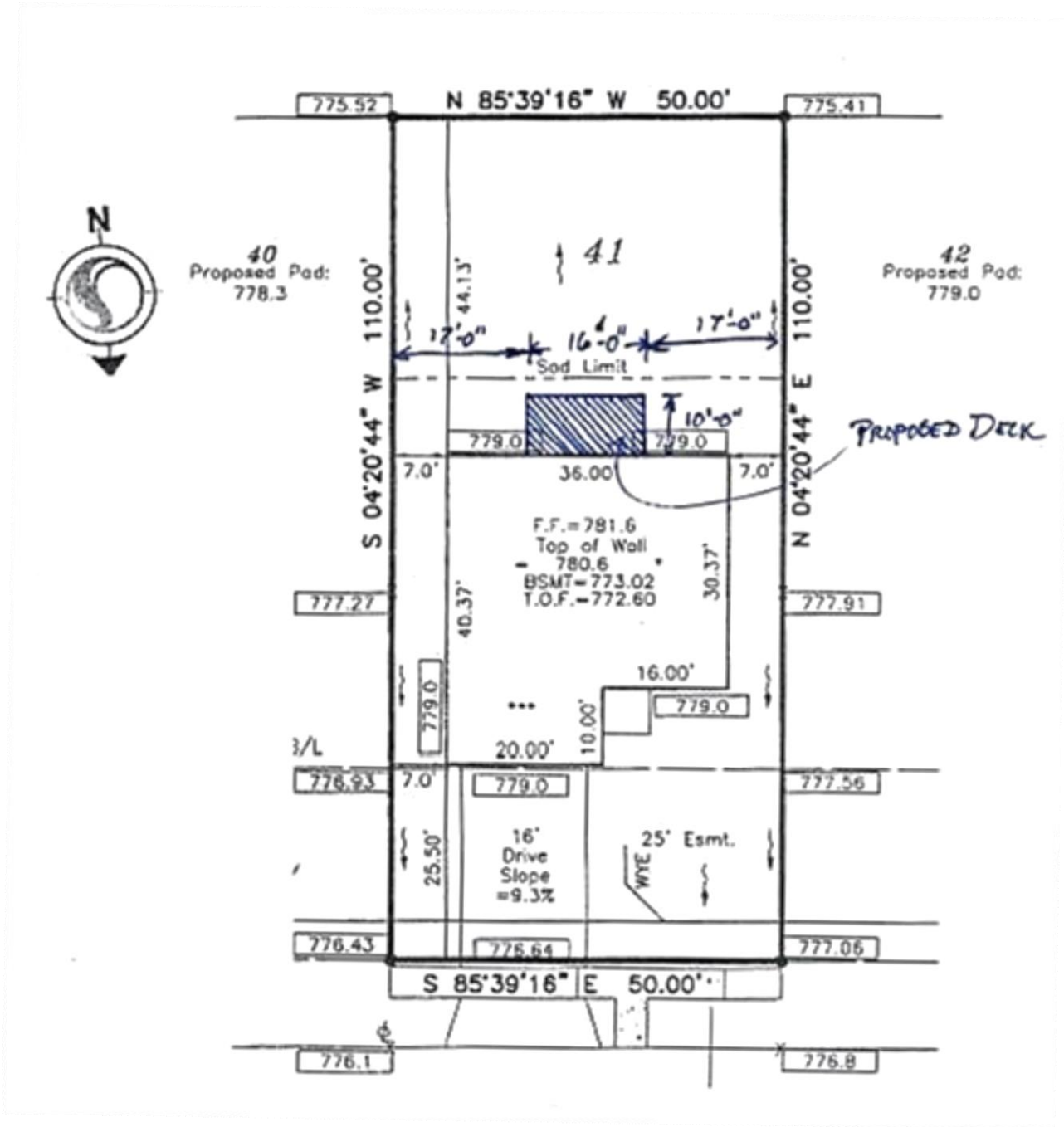

DECK PLANS AND DETAILS

FRAMING PLAN:

1. Plan must show proposed joists and beams with lumber sizes and dimensions between each and any stair locations. It must be drawn and provided independently from this packet. (Example right)
2. Joist spacing must not exceed values in Table 507.7 (first below) based on the type of proposed decking material.
3. Joists are sized based on allowable spans in Table 507.6 (second below).
4. Beams are sized based on proposed joist spans bearing on the beam, and beam span between posts shown in Table 507.5 (third below).
5. Use of LVLs or other engineered beams must be sealed by a design professional or supported by a specification sheet from a lumber company showing that the proposed beam can support the required loads.

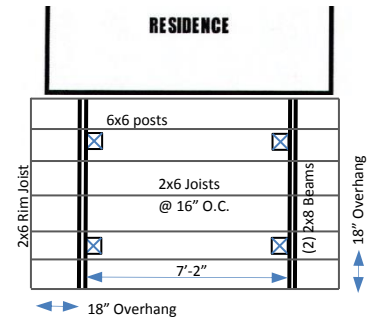

JOIST SPACING:

TABLE 507.7
MAXIMUM JOIST SPACING FOR DECKING

DECKING MATERIAL TYPE AND NOMINAL SIZE	MAXIMUM ON-CENTER JOIST SPACING	
	Decking perpendicular to joist	Decking diagonal to joist ^a
1½-inch-thick wood	16 inches	12 inches
2-inch-thick wood	24 inches	16 inches
Plastic composite	In accordance with Section 507.2	In accordance with Section 507.2

JOIST SIZING:

TABLE 507.6
DECK JOIST SPANS FOR COMMON LUMBER SPECIES (ft. - in.)

SPECIES ^a	SIZE	ALLOWABLE JOIST SPAN ^b			MAXIMUM CANTILEVER ^{c,f}		
		SPACING OF DECK JOISTS (Inches)			SPACING OF DECK JOISTS WITH CANTILEVERS ^e (Inches)		
		12	16	24	12	16	24
Southern pine	2×6	9-11	9-0	7-7	1-3	1-4	1-6
	2×8	13-1	11-10	9-8	2-1	2-3	2-5
	2×10	16-2	14-0	11-5	3-4	3-6	2-10
	2×12	18-0	16-6	13-6	4-6	4-2	3-4

BEAM SIZING:

TABLE 507.5
DECK BEAM SPAN LENGTHS^{a, b, g} (feet - inches)

SPECIES ^c	SIZE ^d	DECK JOIST SPAN LESS THAN OR EQUAL TO: (feet)						
		6	8	10	12	14	16	18
Southern pine	1-2×6	4-11	4-0	3-7	3-3	3-0	2-10	2-8
	1-2×8	5-11	5-1	4-7	4-2	2-10	3-7	3-5
	1-2×10	7-0	6-0	5-5	4-11	4-7	4-3	4-0
	1-2×12	8-3	7-1	6-4	5-10	5-5	5-0	4-9
	2-2×6	6-11	5-11	5-4	4-10	4-6	4-3	4-0
	2-2×8	8-9	7-7	6-9	6-2	5-9	5-4	5-0
	2-2×10	10-4	9-0	8-0	7-4	6-9	6-4	6-0
	2-2×12	12-2	10-7	9-5	8-7	8-0	7-6	7-0
	3-2×6	8-2	7-5	6-8	6-1	5-8	5-3	5-0
	3-2×8	10-10	9-6	8-6	7-9	7-2	6-8	6-4
	3-2×10	13-0	11-3	10-0	9-2	8-6	7-11	7-6
	3-2×12	15-3	13-3	11-10	10-9	10-0	9-4	8-10

Note: Table is based on beams supporting deck joists from one side only. Spans must be reduced for beams supporting joists from 2 sides.

DECK PLANS AND DETAILS

FOOTER PLAN and DETAIL:

1. Plan must show **all** proposed posts and footings with dimensions between each. It must be drawn and provided independently from this packet. (Example right)
2. Footing detail must show diameter and thickness per Table 507.3.1 (below, left).
3. Tributary Area for each post can be found based on the example graphic (below, right).
4. It is acceptable to circle a design below with added dimensions and attach to the plan set (bottom).
5. **All wood structural members to be preservative-treated** in accordance with RCO 317. All posts to be treated, rated, and marked for **ground contact**.

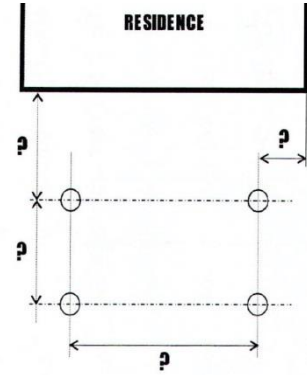

FOOTING SIZE CHART:

LIVE OR GROUND SNOW LOAD ^b (psf)	TRIBUTARY AREA (sq. ft.)	1500 #		
		Side of a square footing (inches)	Diameter of a round footing (inches)	Thickness (inches)
40	20	12	14	6
	40	14	16	6
	60	17	19	6
	80	20	22	7
	100	22	25	8
	120	24	27	9
	140	26	29	10
	160	28	31	11

POST TRIBUTARY AREA:

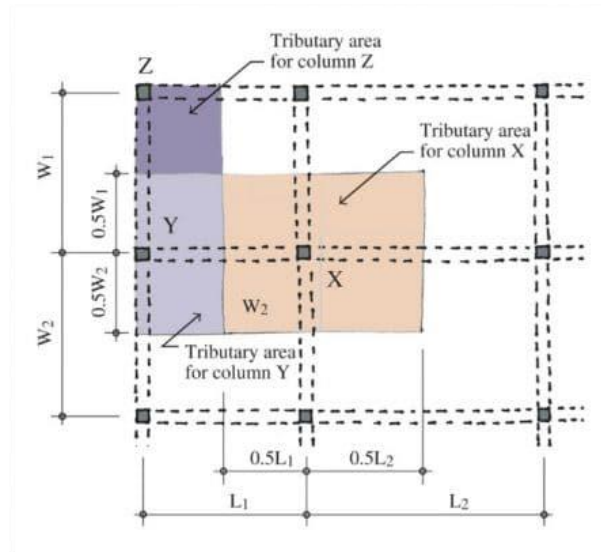

EXAMPLE FOOTING DETAILS:

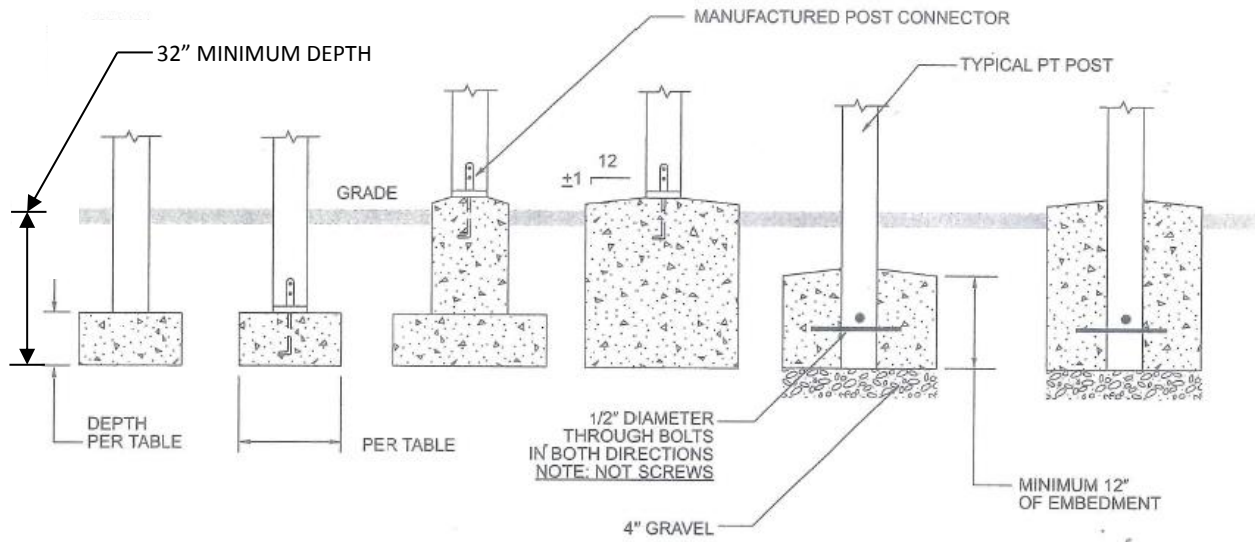

NOTE: POSTS MUST BE CENTERED ON OR IN FOOTING

DECK PLANS AND DETAILS

ELEVATION & DETAILS:

1. Elevation must show proposed height of deck measured from finish grade to deck floor (see examples below).
2. See Table 507.4 (right) for post sizing. Height is measured to the underside of the beam. Wind bracing may be required based on plan review.
3. Elevation detail must show connection methods between members:
 - a. Beams to posts – Beams must bear fully on posts. This requires the use of notched 4x6 or 6x6 posts, or a post cap bracket on 4x4s (see details right and below right).
 - b. Joists to beams - Joist hangers required for flush connections.
 - c. Ledger to dwelling framing (if proposed)

TABLE 507.4
DECK POST HEIGHT^{a, b}

DECK POST SIZE	MAXIMUM HEIGHT ^{a, b} (feet-inches)
4 x 4	6-9 ^c
4 x 6	8
6 x 6	14
8 x 8	14

For SI: 1 inch = 25.4 mm, 1 foot = 304.8 mm, 1 pound per square foot = 0.0479 kPa.
 a. Measured to the underside of the beam.
 b. Based on 40 psf live load.
 c. The maximum permitted height is 8 feet for one-ply and two-ply beams. The maximum permitted height for three-ply beams on post cap is 6 feet 9 inches.

POST CONNECTION REQUIREMENTS:

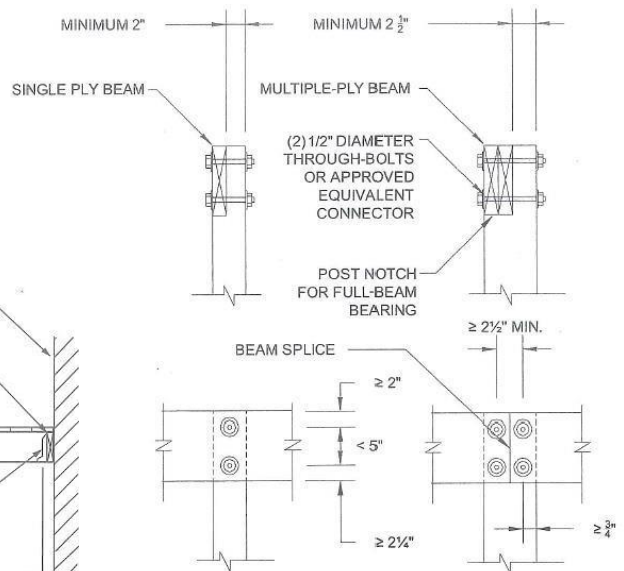

EXAMPLE ELEVATIONS:

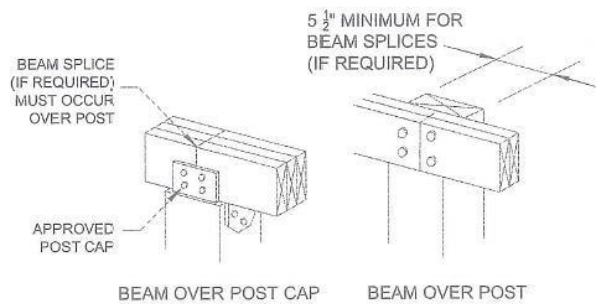
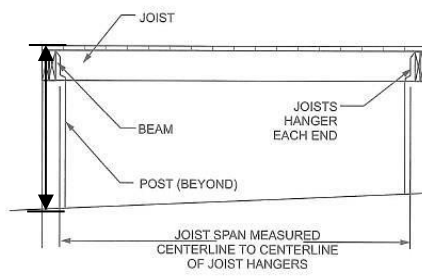
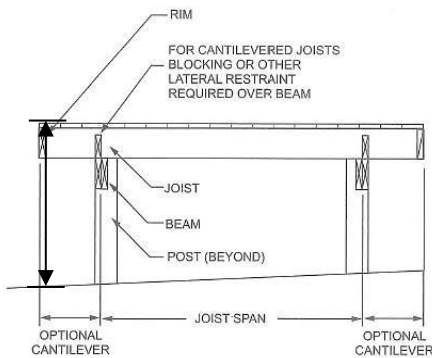
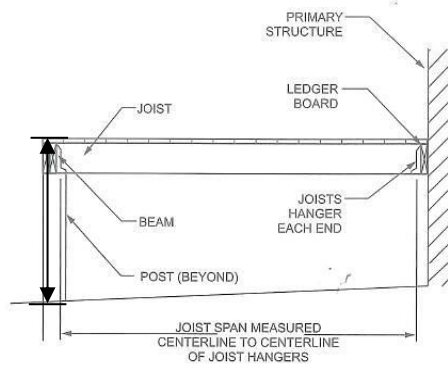
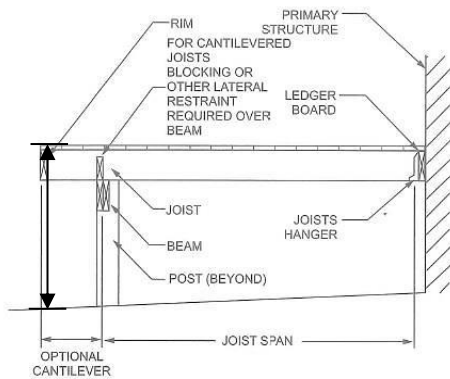

DECK PLANS AND DETAILS

GUARDRAIL, HANDRAIL, STAIR DETAILS:

1. Handrails shall be provided on at least one side of each flight of stairs with four or more risers and shall comply with RCO 311.7.8.
2. Handrail height: No less than 34 inches and no more than 38 inches from tread nosing.
3. Handrails shall be graspable (see examples below)
4. Guard rails **are required** when deck floor height is 30 inches from grade or higher.
5. Guardrails are required to be no less than 36 inches tall and have balusters (vertical or otherwise) that prevent a 4 inch sphere from passing through the openings between balusters.
6. SKIRTING: Where skirting is used, it shall be done in such a manner so as to be not more than 70% opaque (closed). Skirting which is more than 70% opaque must be held 18 inches above grade or be installed in conjunction with a rat wall meeting the requirements of Columbus Building Code (CBC) Section 4123.49. Reference CBC Section 4525.10.

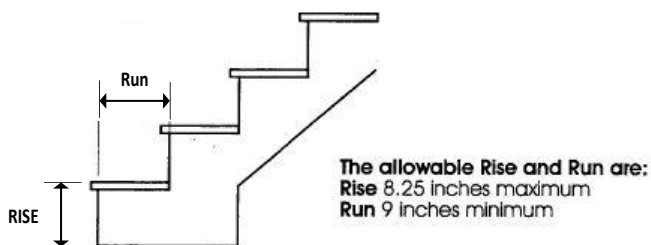

Handrail Grips

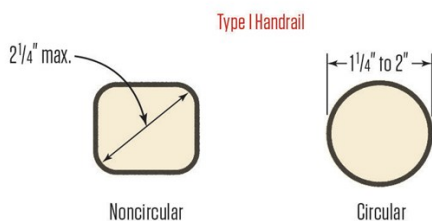

Type II Handrail

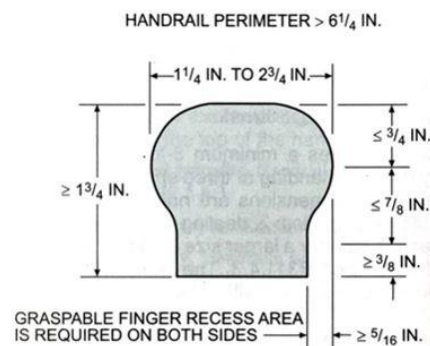
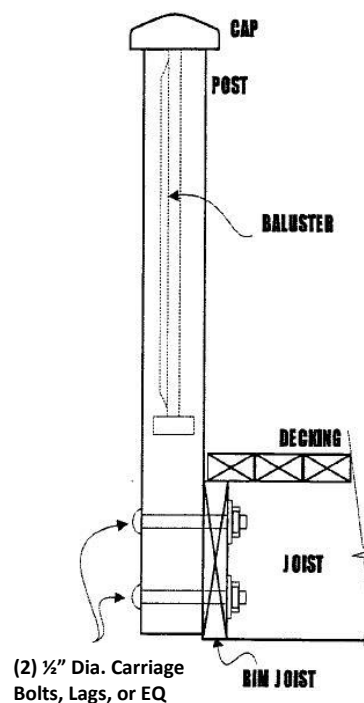
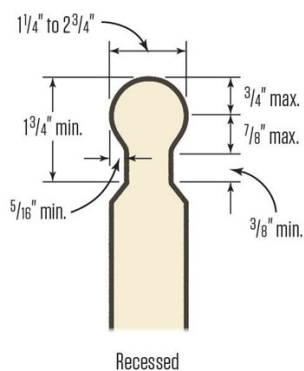

DECK PLANS AND DETAILS

LEDGER DETAILS:

1. Ledgers shall conform to the tables and detail below. It is acceptable to attach this page to plans if using ledger(s).
2. Ledgers attached to masonry veneer will not be permitted. Ledgers on concrete must be fully through bolted. Plans examiner may require the seal of a design professional to verify on site conditions and proposed fastening system.
3. A design professional's seal will be required for the use of expansion bolts.

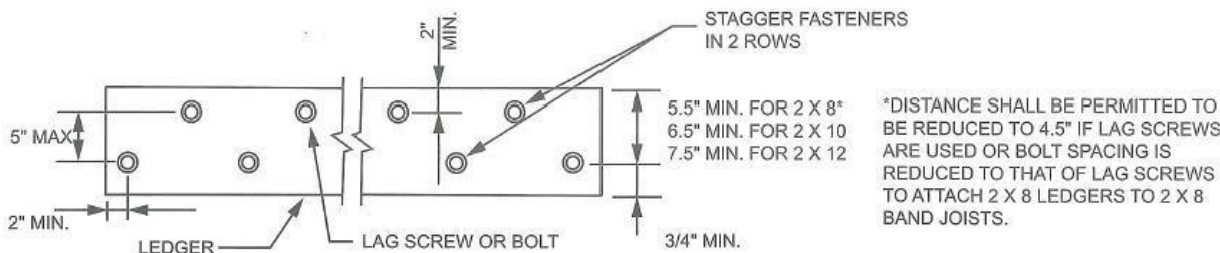
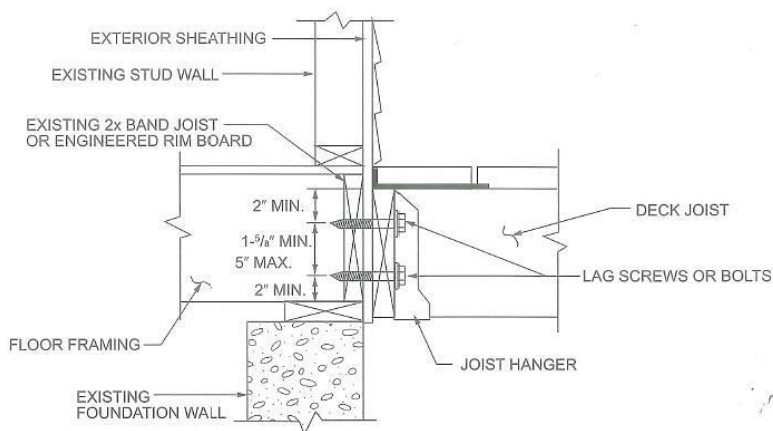

TABLE 507.9.1.3(1)
DECK LEDGER CONNECTION TO BAND JOIST^{a,b}
 (Deck live load = 40 psf, deck dead load = 10 psf, snow load ≤ 40 psf)

CONNECTION DETAILS	JOIST SPAN						
	6' and less	6'1" to 8'	8'1" to 10'	10'1" to 12'	12'1" to 14'	14'1" to 16'	16'1" to 18'
	On-center spacing of fasteners						
1/2-inch diameter lag screw with 1/2-inch maximum sheathing ^{c,d}	30	23	18	15	13	11	10
1/2-inch diameter bolt with 1/2-inch maximum sheathing ^d	36	36	34	29	24	21	19
1/2-inch diameter bolt with 1-inch maximum sheathing ^e	36	36	29	24	21	18	16

- For SI: 1 inch = 25.4 mm, 1 foot = 304.8 mm, 1 pound per square foot = 0.0479 kPa.
- Ledgers shall be flashed in accordance with Section 703.4 to prevent water from contacting the house band joist.
 - Snow load shall not be assumed to act concurrently with live load.
 - The tip of the lag screw shall fully extend beyond the inside face of the band joist.
 - Sheathing shall be wood structural panel or solid sawn lumber.
 - Sheathing shall be permitted to be wood structural panel, gypsum board, fiberboard, lumber or foam sheathing. Up to 1/2-inch thickness of stacked washers shall be permitted to substitute for up to 1/2 inch of allowable sheathing thickness where combined with wood structural panel or lumber sheathing.

TABLE 507.9.1.3(2)
PLACEMENT OF LAG SCREWS AND BOLTS IN DECK LEDGERS AND BAND JOISTS

MINIMUM END AND EDGE DISTANCES AND SPACING BETWEEN ROWS				
	TOP EDGE	BOTTOM EDGE	ENDS	ROW SPACING
Ledger ^a	2 inches ^d	3/4 inch	2 inches ^b	1 5/8 inches ^b
Band Joist ^c	3/4 inch	2 inches	2 inches ^b	1 5/8 inches ^b

- For SI: 1 inch = 25.4 mm.
- Lag screws or bolts shall be staggered from the top to the bottom along the horizontal run of the deck ledger in accordance with Figure 507.9.1.3(1).
 - Maximum 5 inches.
 - For engineered rim joists, the manufacturer's recommendations shall govern.
 - The minimum distance from bottom row of lag screws or bolts to the top edge of the ledger shall be in accordance with Figure 507.9.1.3(1).